

# Optical Label Switched Networks – the FP5-IST STOLAS project

Ton Koonen<sup>1</sup>, Idelfonso Tafur Monroy<sup>1</sup>, J.J. Vegas Olmos<sup>1</sup>, Christophe Peucheret<sup>2</sup>, Jean Jennen<sup>3</sup>, Evi Zouganeli<sup>4</sup>, Erik van Breusegem<sup>5</sup>, Geert Morthier<sup>5</sup>, Jos van der Tol<sup>1</sup>, Tommy Mullane<sup>6</sup>, Kristian Blidegn<sup>7</sup>, Peter Raaby<sup>8</sup>

1: COBRA – Eindhoven Univ. of Technology, 2: Research Center COM – Techn. Univ. Denmark, 3: Lucent Technologies NL, 4: Telenor, 5: INTEC – Univ. of Ghent, 6: Intune Technologies, 7: Hymite, 8: NKT Integration

e-mail: [a.m.j.koonen@tue.nl](mailto:a.m.j.koonen@tue.nl)

## **Abstract**

*Within the STOLAS project, an EC-funded project in the 5<sup>th</sup> Framework Programme which has recently been concluded, an orthogonal optical labeling scheme using Frequency Shift Keying modulation for the 155 Mbit/s label and intensity modulation for the 10 Gbit/s payload data has been explored. This scheme enables to improve the throughput of packet-switched networks by efficient label processing, and by optical routing of the payload of the packet bursts. The label-swapping is done in intensity-driven wavelength converters, deploying cross-phase modulation in SOAs implemented in an MZI configuration. The packet bursts are switched by means of passive waveguide routers, as a function of their wavelength.*

*The paper addresses the networking aspects of this FSK/IM orthogonal labeling scheme, and discusses the advantages and disadvantages when comparing it with alternative schemes. The key components for implementing an orthogonal label-controlled router node are addressed, as well as the node architecture, its economical aspects, and experimental results obtained. The impact of these results on the upgradability and the scalability of a network deploying orthogonal labeling are discussed, and the prospects for application in future high-capacity optical packet-switched networks. A first deployment of this labeling technique may be made in hybrid circuit-packet-switched networks, e.g. for routing of overspill packets.*

## **1. Introduction**

Today's networks show an ever-continuing growth of packet-based data traffic, driven by heavy internet usage, peer-to-peer traffic, gaming, etc. The data traffic in many parts of the networks has already surpassed the voice traffic in volume, but not yet in revenues. How to effectively bill data traffic is a topic of ongoing debates. There is however a consensus that to keep data traffic affordable at these rapidly increasing volumes, the techniques to handle data should become significantly more cost-efficient. Packet-switched data transmission can deploy the network's resources more effectively than the circuit-switched one, as line capacity is only occupied for actual data transport. However, packet switching requires signal processing of the packet routing information in every node, which therefore should be done as efficiently as possible in order to avoid packet traffic jams. The throughput of a node can be increased significantly by routing the payload data transparently through the node without opto-electrical-optical conversion. To control this routing, however, an amount of so-called label information embedded in the data signal is needed, which can be split off the data payload easily



are basically positioned in two independent communication channels. However, obviously a Frequency-Shift-Keying (FSK) modulated label needs non-zero payload signals to be modulated on, and thus the extinction ratio (on/off ratio) of the payload cannot be very high, which compromises the payload receiver sensitivity. Also, due to e.g. interference effects, phase-to-intensity conversions may occur in the transmission link, which cause label-to-payload crosstalk. Using the FSK/IM orthogonal modulation formats for the label and payload data, respectively, can offer an number of advantages: the label and the payload can be easily separated, the label can be readily swapped without affecting the payload, a relatively large bandwidth is available for the label information, no strict synchronization between label and payload is required, a virtually unlimited number of different labels is feasible, and the embedded label channel can also be readily used as a kind of non-intrusive control channel in circuit-switched or hybrid packet-circuit switched networks. The labeling is most efficiently done on an aggregate of packets, a so-called packet burst, in order to have a sufficient payload length to modulate the label on.

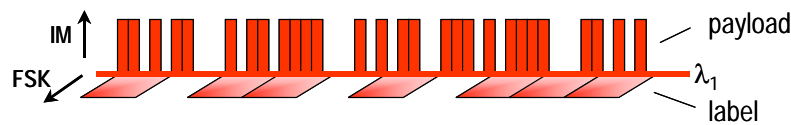

**Fig. 2 Orthogonal packet labeling**

### 3. Comparison with competing technologies

Today's data networks mostly use electronic packet switching (EPS), based on IP/MPLS techniques. Due to the mature integration technologies for electronic circuits, the costs of EPS are relatively low, but will increase significantly when the technologies' speed limits are approached. Optical circuit switching (OCS) is being introduced in data networks presently, based on GMPLS. Due to the extremely high bandwidth of optical transmission, OCS can easily accommodate very high line rates, but is still costly. As market volume grows, however, the OCS costs may come down soon. Optical burst switching (OBS) is in a quite premature state still. At one hand, it offers the speed potential similar to OCS, and at the other hand, a switching granularity comparable to EPS. As the OBS switching speed requirements increase at higher transport capacities, the OBS costs will raise as well, although less steep than for EPS.

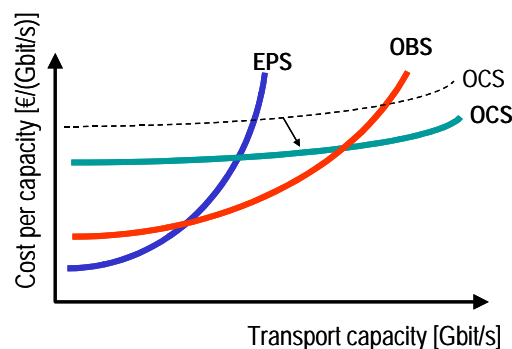

**Fig. 3 Qualitative cost comparison of Electrical Packet Switching, Optical Circuit Switching, and Optical Burst Switching**

Thus, a qualitative cost comparison of EPS, OCS and OBS can be made as shown in Fig. 3. It shows that in principle EPS is most cost-effective at lower transport capacities,

whereas OCS is the best at very high transport capacities. OBS may be the most economic solution in between these regions, i.e. for example in the metropolitan and metro/core networks.

Another study has been made regarding the number of wavelength channels needed to accommodate a certain traffic volume in an OCS and in an OBS network. Basically, in an OCS network separate wavelength paths are established per destination throughout the network from end to end, whereas in an OBS network label switched paths are set per destination of which the individual links may use different wavelengths. Thus, an OBS network basically needs less wavelength channels than an OCS network. In meshed networks, however, the inherently available route redundancy causes the number of wavelengths needed for OCS to be not much higher than the number needed for OBS. In grid networks, on the other hand, the redundancy is lower and thus the wavelength assignment flexibility of OBS pays off by allowing a noticeably lower number of wavelengths being needed than in OCS. The difference, however, is also strongly dependent on the traffic volume and its statistics.

#### 4. STOLAS' building blocks

As shown in Fig. 4, the edge router providing the orthogonal labeling can be based on a fast tunable laser diode of which the wavelength can be set swiftly for wavelength routing, and of which this wavelength can also be modulated by optical FSK in order to affix a label. This label is defined by the label setting circuit based on the header information of the aggregated IP input packets. The continuous wave (CW) output of the FSK modulated light from the laser is subsequently modulated in intensity by the payload data of the burst IP packets.

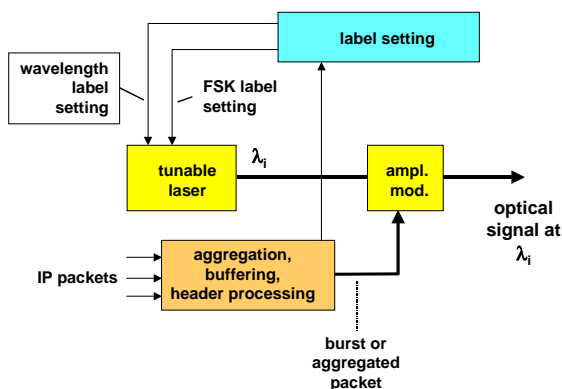

**Fig. 4 Orthogonal labeling in edge router**

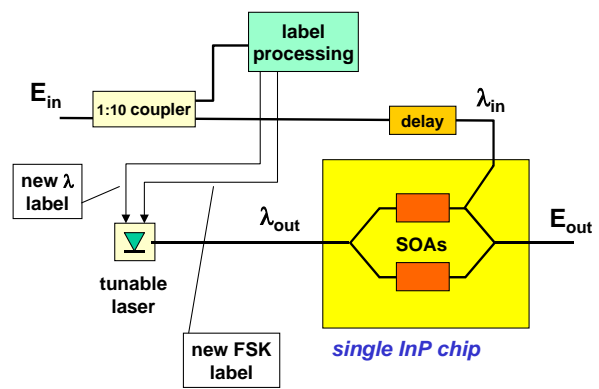
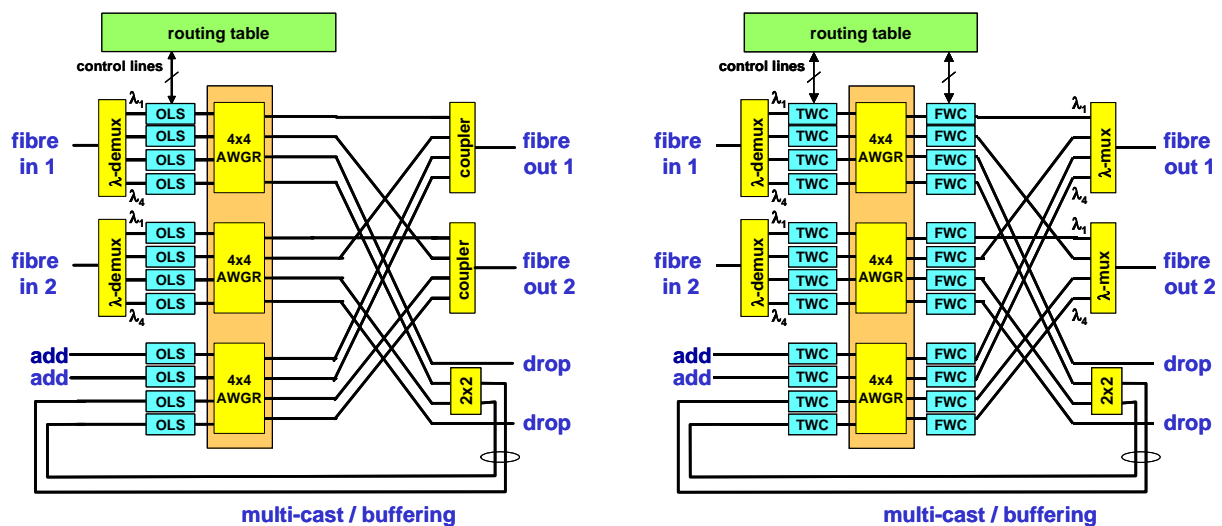

**Fig. 5 Orthogonal optical label swapper**

Swapping of the orthogonal FSK-modulated label needs to be done in the core router. As illustrated in Fig. 5, this can be done by means of a Mach Zehnder Interferometer (MZI) using Semiconductor Optical Amplifiers (SOAs) in its two branches. A small part of the input signal is tapped and fed to the label processing circuit, which reads the label and using a look-up table derives a new FSK label, and controls the corresponding routing required by setting the tunable laser at the appropriate wavelength. The other part of the input signal is fed into one of the SOAs, where it changes its phase shift and thus causes the MZI to get out of balance. Hence the MZI lets the CW light from the tunable laser with the new FSK label at a new wavelength  $\lambda_{out}$  pass. The phase shift of the SOA is only affected by the intensity of the injected light, not by its phase nor

frequency. Therefore only the intensity modulation of the incoming signal is transferred from the old wavelength  $\lambda_{in}$  to the new one  $\lambda_{out}$ , but the old FSK label is erased. Thus swapping of the FSK label and conversion to a new wavelength is achieved.

Using this optical label swapper (OLS) circuit, a modular label-controlled optical router can be set up as shown in Fig. 6.a. In the OLS, the FSK label is swapped and a new wavelength is set. The actual signal routing is done in passive wavelength routers (Arrayed Waveguide Grating Router, AWGR), which guide the signal from an input port to a specific output port depending on the wavelength of the input signal. The router has two input fibre ports and two output ones, and two add ports and two drop ports for adding or dropping data packets locally at the node. Also a multicasting functionality is supported, which may be used for e.g. implementing multiparty video conferencing or virtual private networks. This multicasting function is realised by feeding the signals from the dedicated multicast output ports of the AWGRs via a 2x2 coupler to two input ports, from where they are routed through the AWGRs to the appropriate output fibres by setting the OLSs accordingly. The modular setup of the router allows easy scaling to more fibre ports and/or more wavelengths per fibre. As the central routing element, the AWGRs, is fully passive, the router does not have a single active point of failure, and thus can be highly reliable.



a) Basic node architecture

b) Non-blocking node architecture

Fig. 6 STOLAS Label-controlled routing node

The basic node of Fig. 6.a may suffer from blocking: collisions may occur between packet bursts which are converted to the same wavelength in order to enter a common output fibre. In order to make the node non-blocking, i.e. to avoid these collisions, a second set of wavelength converters (with fixed output wavelength; FWC) can be applied after the AWGR, as shown in Fig. 6.b. The tunable wavelength converters (TWC-s) at the inputs of the AWGR set the wavelength for appropriate routing through the AWGR, and also erase the FSK label. In each FWC, by FSK modulating the CW output of the tunable pump laser, new labels can be affixed to the outgoing packet bursts. The passive router is composed in a modular way of multiple AWGRs, which enables scaling of the node to more input/output fibres and wavelength channels.

## 5. Experimental results

As mentioned before, for adequate detection of the FSK label the extinction ratio (ER) of the IM payload should not be too high. On the other hand, a low ER causes a penalty for detection of the payload. Hence the optimum ER is a compromise, depending on the payload data rate and the label data rate. Measurements have been done in the system setup of Fig. 7, with the IM payload being a 10 Gbit/s PRBS  $2^7-1$  signal. The FSK labeling was done at 50 Mbit/s and at 312 Mbit/s, with a tone spacing of 20 GHz allowing single-filter demodulation.

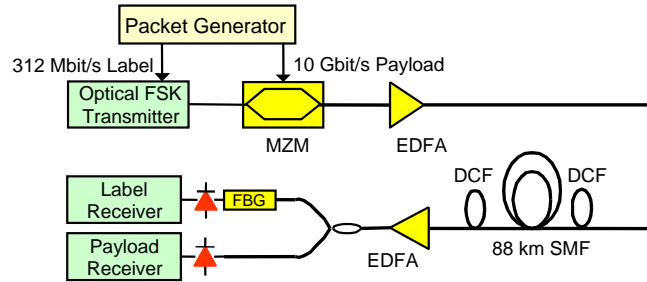
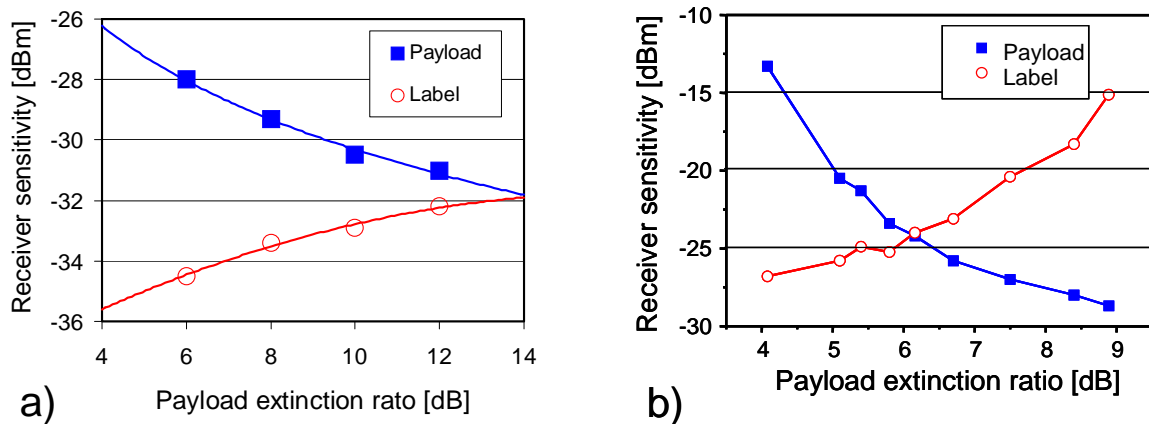

**Fig. 7 IM/FSK payload/label transmission testbed**

### 5.1 Impact of payload extinction ratio

Fig. 8.a shows how the receiver sensitivities for the IM payload and for the FSK label vary at the 50 Mbit/s label rate, when the payload extinction ratio (ER) is increased from 6 to 12 dB. The label receiver sensitivity then degrades by 2 dB, whereas the payload receiver sensitivity improves by more than 3 dB. The optimum ER is found to be around 14 dB. At the higher label rate of 312 Mbit/s, the degradation of the label receiver sensitivity with increasing ER is more pronounced, because less payload bits per label bit are available. As shown in Fig. 8.b, this yields a lower optimum ER (about 6.5 dB), and hence a degraded IM payload receiver sensitivity [4]. The eye patterns for the 10 Gbit/s payload and the 312 Mbit/s label data are shown in Fig. 9.

Next to lowering the label rate, applying Forward Error Correction coding (FEC) on the label allows to increase the ER, and thus to improve the link budget.



**Fig. 8 Impact of payload extinction ratio at a) 50 Mbit/s FSK label rate , b) 312 Mbit/s FSK label rate**

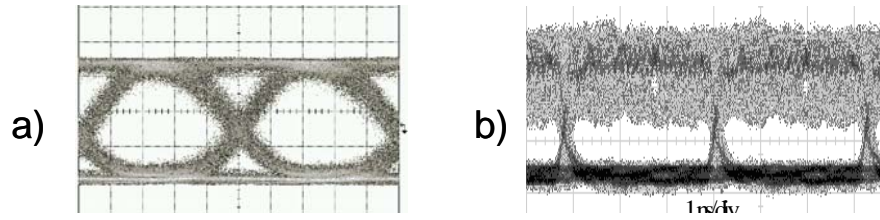

**Fig. 9** Detected eye pattern of a) the 10 Gbit/s payload and b) the 312 Mbit/s label, at the respective receivers

## 5.2 Scalability

In order to assess the scalability of the label-swapping concept, experiments have been done with putting two label-swapping TWCs in cascade, using an ER of 7 dB and of 12 dB. Four wavelength channels were used, with a spacing of 200 GHz (1555.75, 1557.36, 1558.98, and 1560.61 nm). The payload BER measurement results are shown in Fig. 10. Passing through a single TWC, a power penalty at BER= $10^{-9}$  is incurred of 2.7 dB for an ER=7 dB, and of 1.9 dB for ER=12 dB. Passing two TWCs, the penalties are 5.3 dB and 4.4 dB, respectively. These cumulative penalties are largely due to insufficient speed of the SOAs inside the TWC, which cause patterning effects. With a payload rate of 10 Gbit/s, and a dynamic range of 20 dB for the payload receiver, the insufficient TWC speed limits the cascadability to 4 nodes. At a lower payload speed of 2.5 Gbit/s, the penalties are found to be remarkably lower (<2 dB after passing 6 nodes); hence much more nodes could be cascaded.

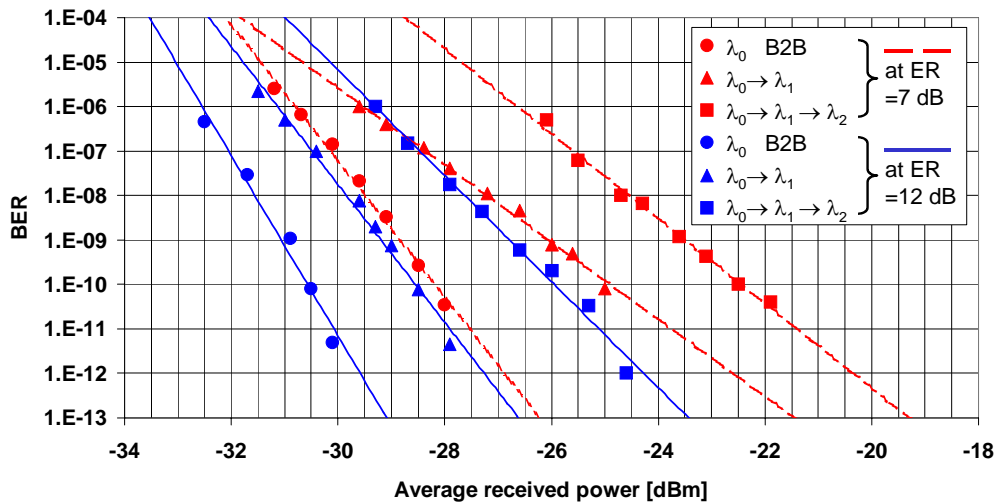

**Fig. 10** Payload BER performance when cascading TWCs, for ER=7 dB and =12 dB

## 6. STOLAS application example: overspill routing

As a first example how the STOLAS orthogonal packet labeling could be deployed in a practical network, the orthogonal labeling of overspill packets in a hybrid OCS/OBS network has been explored. This so-called ORION (Overspill Routing In Optical Networks) [5] application is exemplified in Fig. 11.

Assume that 13 Gbit/s data packet traffic is to be sent from node A to B, whereas a single wavelength channel  $\lambda_0$  can only carry 10 Gbit/s. To realise this, one may route the excess 3 Gbit/s on a second wavelength channel  $\lambda_1$  from A to C and then via  $\lambda_0$  to

B. This deflection routing solution uses quite some extra resources on the link B-C, and may fail when C already had to send say 9 Gbit/s to B. A more efficient solution is the ORION one, where the 3 Gbit/s excess packets are orthogonally labeled as being overflow packets and sent from A to B on  $\lambda_1$ . At B, these are recognised as being overflow packets meant for B, and are dropped at B, thus avoiding additional load on the link B-C. Simulations have shown that remarkable throughput gains can thus be reached [6].

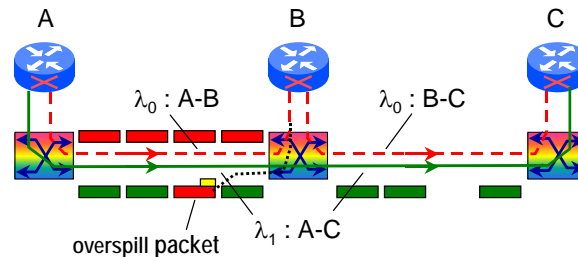

**Fig. 11 Labeled overflow routing**

## 7. Conclusions

By means of orthogonal labeling, the routing of data packets can be efficiently handled in core network routers while leaving the payload data in the optical domain. Thus, avoiding opto-electrical/optical processing bottleneck of the payload, the throughput of these routers can be significantly increased. By using fast tunable lasers and passive wavelength routing elements, a scalable modular router node with high reliability can be realised. The orthogonal FSK label swapping and wavelength conversion can be efficiently done in MZI wavelength converters. An attractive first application may be the labeled routing of overflow packets in a hybrid OCS/OBS network.

## 8. Acknowledgement

All partners in the STOLAS project are gratefully acknowledged for their contributions, as well as the European Commission for partly funding it.

## References

- [1] D.J. Blumenthal et al., "All-optical label swapping networks and technologies", IEEE J. of Lightwave Technol. Dec. 2000, pp. 2058-2075
- [2] Ton Koonen, Geert Morthier, Jean Jennen, Huug de Waardt, Piet Demeester, "Optical packet routing in IP-over-WDM networks deploying two-level optical labeling", Proc. of ECOC 2001, Amsterdam
- [3] K. G. Vlachos, I. T. Monroy, A. M. J. Koonen, C. Peucheret and P. Jeppesen, "STOLAS: Switching Technologies for Optically Labeled Signals", IEEE Communications Magazine, vol. 41, no. 11, pp. 43-49, 2003
- [4] J. Zhang, N. Chi, P. V. Holm-Nielsen, C. Peucheret and P. Jeppesen, "An optical FSK transmitter based on an integrated DFB laser/EA modulator and its application in optical labeling", IEEE Photonics Technology Letters, Vol. 15, No. 7, pp. 984-986, 2003
- [5] E. Van Breusegem, D. De Winter, J. Cheyns, D. Colle, S. Van den Berghe, M. Pickavet, J. Moreau, P. Demeester, "Experimentation with the ORION emulator", Proc. of NOC 2005, July 5-7, 2005, London
- [6] J. Cheyns, E. Van Breusegem, D. De Winter, R. Van Caenegem, D. Colle, M. Pickavet, P. Demeester, "A detailed look on ORION: traffic simulations on a node level", Proc. of NOC 2004, June 29-July 2, 2004, Eindhoven, pp. 474-481